

MEET THE CODE, MAXIMIZE PERFORMANCE, AND KEEP COSTS DOWN

John Wiles

In the last installment of Code Corner, the reasons for applying the National Electric Code (NEC) to photovoltaic power systems were discussed. Some of the whys and hows for those who have decided to install safe PV systems which comply with the Code will now be reviewed.

AC Power Systems vs DC Power Systems

The NEC does not establish requirements for protecting components such as PV modules, charge controllers, inverters, and various appliances connected as loads. The Code assumes that these devices are designed to protect themselves and the user from electrical shock and fire. When a component device has been tested and listed by Underwriters Laboratories (UL), it will meet numerous standards that result in reasonably safe operation and yield a device that can be connected to other UL listed components without problems. This is the story of the alternating current power systems that are in use every day -- UL listed wire, UL listed outlets, UL listed appliances, UL listed load centers, etc. All systems work together and can be safely connected with only a little training and experience because the interface standards between each component are established and controlled by one agency -- UL.

Unfortunately, in PV power systems there are few UL listed products and therefore the standards and the interface control that UL listing implies do not exist. The National Electric Code is the only recourse available for designing and installing PV systems with some degree of safety.

Overcurrent Protection for Conductors, Not Equipment

The system installed in accordance with the Code will have every conductor protected with an overcurrent device. If any conductor is shorted to a conductor of the opposite polarity at any place in the system, an overcurrent device will open and prevent any damage. Fuses and circuit breakers inside inverters and charge controllers generally do not protect the wiring, but are designed to protect the device itself.

For this reason, overcurrent devices are needed between the battery and the PV array to protect the array wiring; between the battery and the inverter to protect that wiring; and between the battery and the loads to protect the load wiring.

Disconnects For Safety

In order to adjust and service the various electronic components in a PV power system, the NEC requires that disconnects be used to cut off voltage/current to those same devices requiring wiring overcurrent protection.

This presents a strong rationale for using dc-rated, UL listed circuit breakers for both the disconnect function and the overcurrent protection. As mentioned previously, Square D residential ac circuit breakers can be used on systems with open circuit voltages up to 48 volts (12 and 24 volt systems) and current requirements up to 70 amps. This would include systems with 12-volt, 600-watt inverters. Square D products have the advantages of widespread availability and factory manufactured load centers to hold the breakers. If higher currents are needed, Heinemann or Airpax

circuit breakers can be used, but they are special order items and custom enclosures must be used. Airpax has dc rated, UL listed circuit breakers with a voltage rating up to 125 volts dc and current ratings up to 100 amps. Heinemann has UL listed breakers at 125 volts and higher with current ratings up to 700 amps! Caution must be exercised when using UL recognized breakers as they are not approved for branch circuit protection and generally have low short-circuit interrupt capabilities.

Separate The Charge and Discharge Circuits

In previous Code Corner discussions, it was noted that the charging and discharging conductors from the battery should be separate circuits to prevent open circuit PV voltages from being inadvertently applied to the load. A circuit from the battery to the charge controller/PV source circuits with a breaker in it is needed. Another breaker would be needed in a circuit between the battery and the dc load circuits and possibly a third between the battery and the inverter if any. Here is the reasoning for three circuits.

Short Circuits Can Be Destructive

The batteries can deliver extremely high levels of current under short-circuit conditions. The levels of current are so high that standard fuses and circuit breakers will be destroyed when subjected to these currents and there is danger in the flying shrapnel released when they blow apart. For this reason, it is important to use current limiting fuses near the battery in the circuit to the charge controller and in the circuit to the dc loads. These current limiting fuses will protect the circuit breakers used in the PV source circuits and the multiple circuit breakers used in the dc load center.

Since the inverter may draw large currents and is on a separate circuit, a special circuit breaker can be used which has the interrupt capability of 25,000 amps at 65 volts dc. This breaker does not have to be protected by a current limiting fuse and by holding the number of devices in this circuit to a minimum, the inverter performance is maximized. Heinemann can supply these breakers with a UL listing up to 110 amps and a factory listing up to 250 amps at 65 volts dc. In fact, if all of the circuits were protected by circuit breakers with this high interrupt rating, there would be no need for the current limiting fuses -- but the cost would be much higher than using Square D QO breakers where appropriate in the other circuits.

The figure below shows how the proper components might be connected for lowest cost and maximum performance. The two-pole breaker connected before and after the charge controller needs to be a two-pole unit only if the controller is sensitive to the power connection sequence or should not be connected to the batteries or the PV array alone. The breaker in front of the controller is needed to disconnect the PV input. The controller

A LOW COST, HIGH CURRENT PV DISCONNECT SYSTEM
MEETING NEC REQUIREMENTS

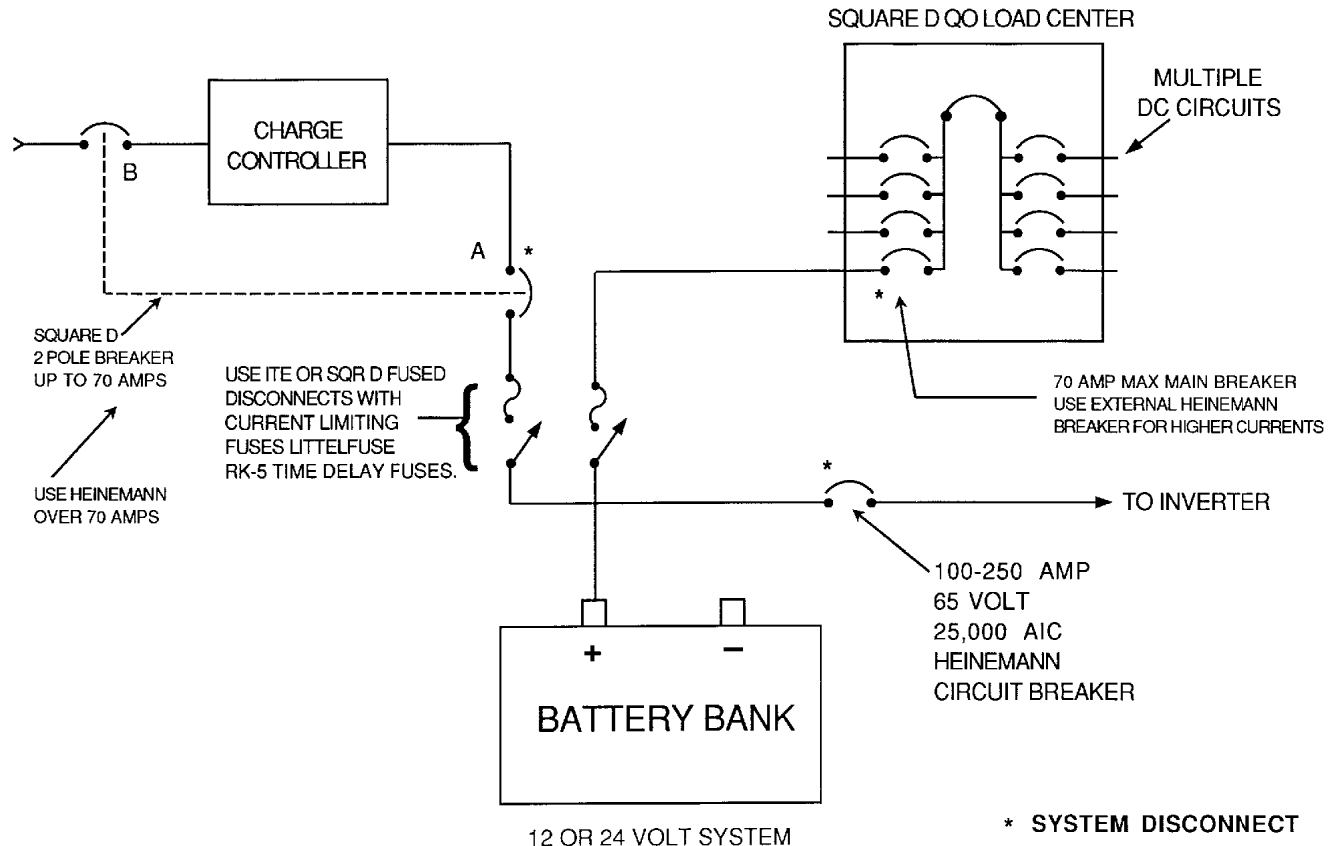

could be isolated from the battery (for servicing) with the fuse disconnect switch if the second pole of the two-pole circuit breaker is not used. The system disconnects must be grouped together so it is probably best to use the two-pole unit because the fuse disconnect switch should be located close to the battery.

In this 12 or 24 volt system, Square D QO breakers up to 70 amps could be used in all locations except between the battery and the inverter. This location requires a breaker that can handle currents higher than 70 amps and could be a Heinemann CD (up to 110 amps) or GJ (up to 250 amps) breaker. A custom box would be needed.

The circuit configuration shown meets the requirements of the NEC, provides protection from accidental over voltage on the loads, maximizes inverter performance and holds costs to a minimum. In the next Code Corner, load circuits will be discussed.

Access

John Wiles, Southwest Region Experiment Station, PO Box 30001/Dept 3SOL., Las Cruces, NM 88003 505-646-6105.

Heinemann Electric Company 609-882-4800 Ask for applications engineering

Airpax 301-228-4600 Ask for applications engineering



SOLAR ELECTRICITY TODAY

The best resource guide & directory of suppliers, mail-order catalogs, books, and PV information. Over 600 sources-\$7. From PV Network News • 11 years old this year!

**2303 Cedros Circle
Santa Fe, NM 87505
505-473-1067**