

SAFETY ALERT

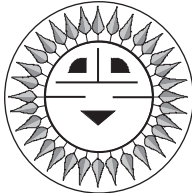

John Wiles

A potential safety problem exists when a stand-alone 120-volt inverter is connected to a house or other structure wired for 120/240-volt alternating current. All PV Dealer/Installers and individuals who have installed such systems should review the following information carefully and take corrective actions where necessary.

Stand-alone PV and PV/Hybrid systems are frequently connected to a building, structure, or house that has been previously completely wired for 120/240-volts ac and has a standard service entrance and load center.

These structures may employ one or more circuits that the National Electrical Code® (NEC®) identifies as a multiwire branch circuit. See Section 100 in the NEC, "Branch Circuit, Multiwire" for a complete definition. These circuits take a three-conductor-plus-ground feeder from the 120/240-volt load center and run it to the loads in the structure where two separate 120-volt branch circuits are split out. Each branch circuit uses one of the 120-volt hot, ungrounded conductors from the 120/240-volt feeder and the common neutral conductor.

In a utility-connected system or a PV system with a 120/240-volt stacked pair of inverters, the 120/240-volt power consists of two 120-volt lines that are 180 degrees out of phase. The currents in the common neutral in the multiwire branch circuit are limited to the difference in currents from any unbalanced load. If the loads on each of the separate branch circuits were equal, then the currents in the common neutral would be zero.

A neutral conductor overload may arise when a single 120-volt inverter is tied to both of the hot input conductors on the 120/240-volt load center. This is a common practice for stand-alone PV homes and I do it in my house. At this point, the two hot 120-volt

conductors are being delivered voltage from the single 120-volt inverter and that voltage is in phase on both conductors. In the multiwire branch circuits, the return currents from each of the separate branch circuits *add* in the common neutral. A sketch of the multiwire branch circuit is presented below. Additional information can be found in the NEC in Sections 100, 210-4, 240-20(b), and 300-13(b), and in the NEC Handbook.

Each branch circuit is protected by a circuit breaker in the ungrounded conductor in the load center. The neutral conductor is usually the same size as the ungrounded conductors and can be overloaded with the in-phase return currents. The circuit breakers will pass current up to the ampacity of the protected conductors, but when both branch circuits are loaded more than 50%, the unprotected, common-neutral conductor is *overloaded and may be carrying up to twice the currents that it was rated for.*

A definite fire and safety hazard exists. All existing stand-alone PV installations using single inverters tied to both ungrounded conductors at the service entrance should be examined for multiwire branch circuits.

The NEC requires that multiwire branch circuits in *some, but not all, cases* have the two circuit breakers tied together with a common handle (or use a two-pole circuit breaker) so that both circuits are dead at the same time under fault conditions and for servicing. This common-handle, side-by-side circuit breaker rated at 15 or 20 amps may be one indication that multiwire branch circuits have been used. Common handle circuit breakers rated at 30 amps and higher are usually dedicated to 240-volt circuits for ranges, hot water heaters, dryers, and the like.

Examination of the wiring in the load center may show a three-wire cable (14 or 12 AWG conductors) with a bare equipment grounding conductor leaving the load center. This may be connected to a multiwire branch circuit. The circuit breakers connected to this cable and the outputs of this cable should be traced to determine the presence or absence of a multiwire branch circuit.

The multiwire circuits must be disconnected or rewired as separate circuits ("home runs") from the load center. Another option is to limit the output of the inverter with a circuit breaker rated at the ampacity of the neutral conductor (usually 15 amps).

With 4000 watt (33-amp) inverters, a 15-amp circuit breaker on the output will certainly limit the output but won't be very popular (only half power output).

A copy of a draft proposal for the 1999 NEC is presented below that addresses this problem.

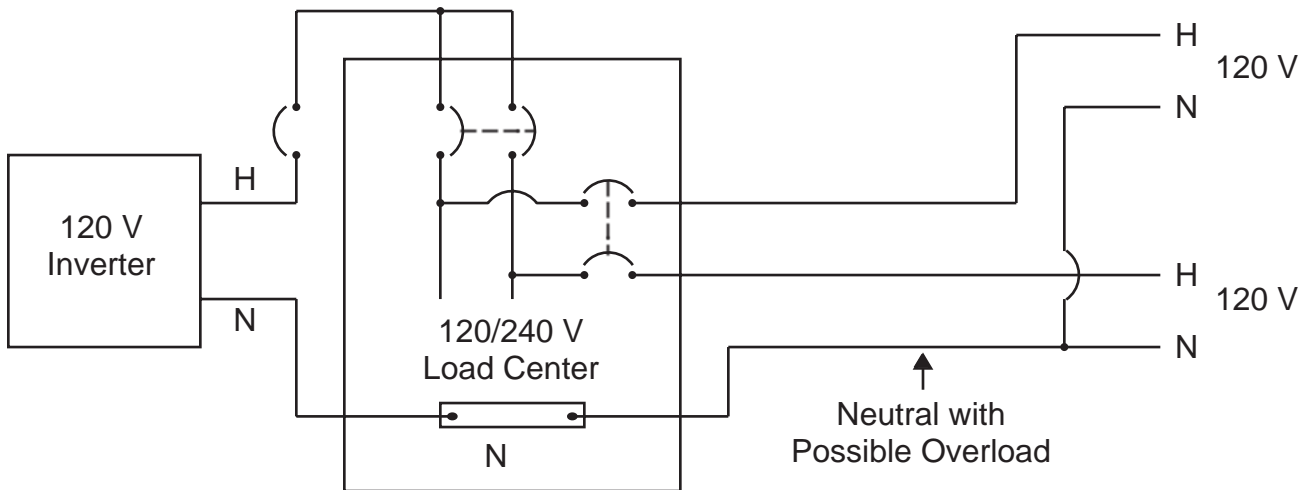

Diagram of a multiwire branch circuit

Draft Proposal for the 1999 National Electrical Code

This draft proposal, if accepted, will provide exceptions to NEC Section 690-14. This section requires that PV systems comply with the provisions of NEC Article 230, Part F, which covers service entrances. Some electrical inspectors are raising the issue that if a house is wired with a 120/240-volt service entrance at 100 amps, then the PV system must supply 120/240 volts at 100 amps — that would require a \$240,000 PV system! Exception 3 to Section 690-14 will permit the PV system to deliver power (current) to the house at less than the rating of the service entrance. Exceptions 4 & 5, shown in the next paragraphs, will allow a 120-volt inverter to feed a 120/240-volt service entrance. The Exceptions are followed by substantiation for the Code Making Panel that must vote on the proposal.

Draft Exception

Exception No. 4: The inverter output of a stand-alone photovoltaic power source shall be permitted to supply 120 volts to a single-phase, three-wire 120/240-volt service entrance or main disconnect when there are no 240-volt outlets and when there are no multiwire branch circuits. In all installations, the rating of the output overcurrent device connected to the photovoltaic inverter shall be less than the rating of the neutral conductor in the load center or service disconnect device in the structure.

Exception No. 5: Where 120-volt multiwire branch circuits are present, the output overcurrent device connected to the photovoltaic inverter shall be rated at no more than the ampacity of the smallest common neutral conductor in the multiwire branch circuits.

Substantiation

Most inverters in stand-alone photovoltaic power

systems have a single 120-volt output. It is common practice to connect this single output to both (in parallel) ungrounded conductors of a single-phase 120/240-volt, three-wire load center and supply current in phase to all 120-volt outlets and appliances. If 240-volt loads were inadvertently connected to the premises wiring, there would be no safety issue since the two ungrounded conductors have voltages that are in phase which would supply the 240-volt connected device with zero volts.

Some residences and other structures are wired with multiwire branch circuits where the two ungrounded conductors of the 120/240-volt single-phase system supply current to separate 120-volt circuits with a common return neutral conductor. If both 120-volt circuits were connected to loads, the return currents in the neutral would be in phase when driven by a 120-volt inverter and this could cause an overloaded neutral conductor while not tripping any overcurrent device. These exceptions recognize this condition and prevent the connection if multiwire branch circuits are present. If they are present, then limiting the maximum current delivered by the inverter through the use of an appropriate overcurrent device will protect the neutral conductors.

It is possible, though unlikely, that a large inverter could be connected to a small load center and overload the neutral in the load center. The last sentence in Exception 4 prevents this from happening.

Summary

There are houses and other buildings that are wired with multiwire branch circuits. The practice is quite common in some areas of the country. Please check your existing installations.

If anyone determines that multiwire branch circuits are common practice in a certain part of the country, please share that information widely and notify me.

Please distribute this article as widely as possible throughout the PV community.

Access

Author: John C. Wiles • Southwest Technology Development Institute • New Mexico State University • Box 30,001/ Department 3 SOLAR • Las Cruces, NM 88003 • Phone 505-646-6105 • FAX 505-646-3841

An NEC Article 690 Task Group, chartered by NFPA, is working on the 1999 NEC with a Technical Review Committee from the Solar Energy Industries Association (SEIA). Those wishing to actively participate should contact Ward Bower at Sandia National Laboratories • 505-844-5206

National Electrical Code ® and NEC ® are registered trademarks of The National Fire Protection Association. The 1996 NEC and the NEC Handbook are available from the NFPA • 1 Batterymarch Park • Quincy, MA 02269-9101 • 800 344-3555 • 617-770-3000



Off The Shelf

The spec sheet directory of renewable electricity

300+ pages, 12 Chapters

"*Off the Shelf* is great for people seriously interested in solar photovoltaic technology who want to know the specifics of the available equipment. This product literature looseleaf is stuffed with information of current state-of-the-shelf photovoltaic system components. We recommend it to all our workshop participants." Johnny Weiss, Director, Renewable Energy Education Program. **Solar Energy International**, Carbondale CO.

"*Off the Shelf* is a must for systems designers, trainers, or those who are thinking of their own system." Paul Maycook, publisher, **PV News**.

"Overall, this is a great effort to pull together a comprehensive of manufacturers and dealers. I look forward to the next edition." Art Boyd, **MARETC, Crowder College**, MO.

"I use it almost every day." Windy Dankoff, **Dankoff Solar Products**.

"This Book is the answer for designers of renewable energy systems...just about every manufacturer in the RE industry...and an appendix listing hundreds of dealers and installers of RE products." Richard Perez, editor, **Home Power Magazine**.

The Cost is \$69.95 including book rate postage.
Outside U.S. inquire

The PV Network News

2303 Cedros Circle, Sante Fe, NM 87505

Voice/fax: 505-473-1067 • e-mail: pvpaulset@aol.com

Our 16th Year of PV-Powered Publishing



Back Issues of Home Power !

Check out HP#53... It contains an index of all articles back to issue #1.

You can buy back issues individually:

- \$3.25 each for #11, #13, and #16 through #20
- \$4.75 each for #21 through #45 (except for #36)
- \$5.75 each for #46 through #54

Or

Deal #1: All 40 available issues for \$127

Deal #2: 6 or more issues (of #21 through #54) for \$4.00 each (*sent bound printed matter*).

for U.S. ZIP codes only, see page 81 for international back issues.

(Sorry, we're out of issues 1 through 10, #12, #14, #15 and #36). We are planning to compile them into a book. Until then, borrow from a friend. If you have a computer (or a friend with one) download the article you're missing by calling the Home Power bulletin board at 707-822-8640. Or check with your local library; through interlibrary loan, you can get these back issues. Jackson County Library in Oregon has all issues as does the Alfred Mann Library at Cornell Univ.)

Home Power, PO Box 520, Ashland, OR 97520 • 800-707-6585 • 916-475-0830 VISA / MC

